



FIGURE 1: Individual Shield Adapter on the cable, shields dressed ready for termination.



FIGURE 3: Individual Shield Adapter Body assembled to connector, Friction Ring and Nut tightened on Adapter Body with Shield Pigtaills dressed behind the adapter.



FIGURE 2: Individual Shield Adapter Body assembled to connector, shields dressed through the Iris.



FIGURE 4: Completed Assembly of individual shields terminated with Iris Adapter.

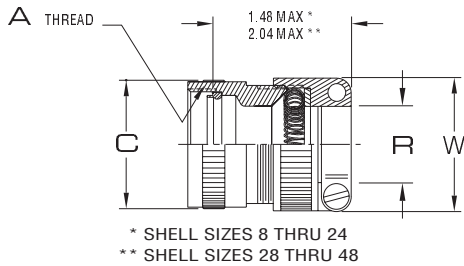

ROTATING BODY STYLE

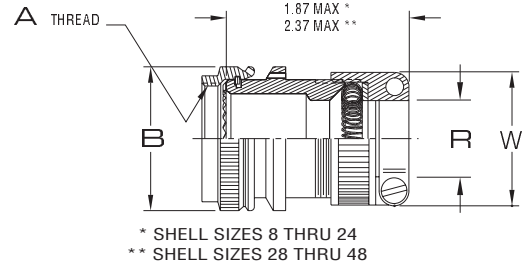

NON-ROTATING BODY STYLE

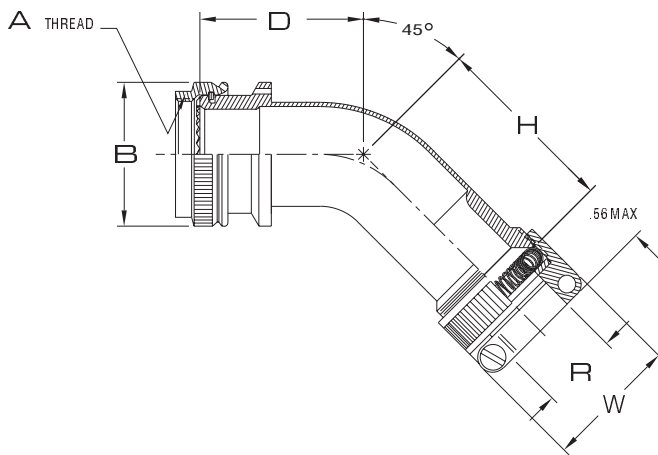

45° STANDARD BODY STYLE

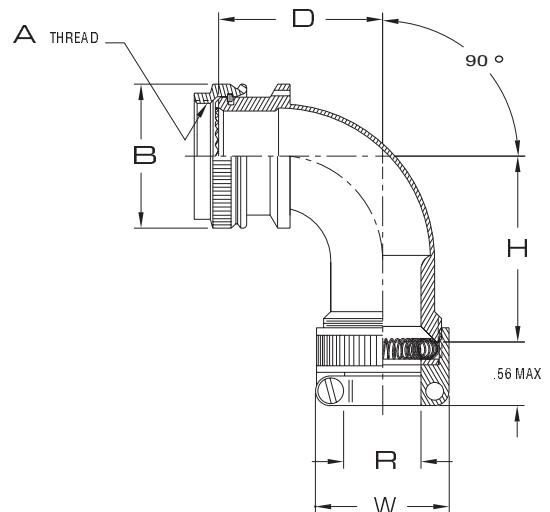

90° STANDARD BODY STYLE